

7520 series Wall mount enclosures

No design charges - No tooling

Simply provide your internal dimensions for a free quotation

Product overview

Wall mount enclosures manufactured in custom sizes to fit your PCB assembly and components.

Features

- 2-U-shape snap together flanged construction
- Wall mounted via flanged sides
- Manufactured to your custom specifications
- Various material colour and specification options
- Manufactured to order on short lead-times

Options

- Manufactured in either HIPS UL94-HB, ABS acrylic capped or listed ABS UL94-V0
- CNC milling (holes, cut-outs, vents, pockets, pillars, windows)
- Screen printing/membranes/overlays

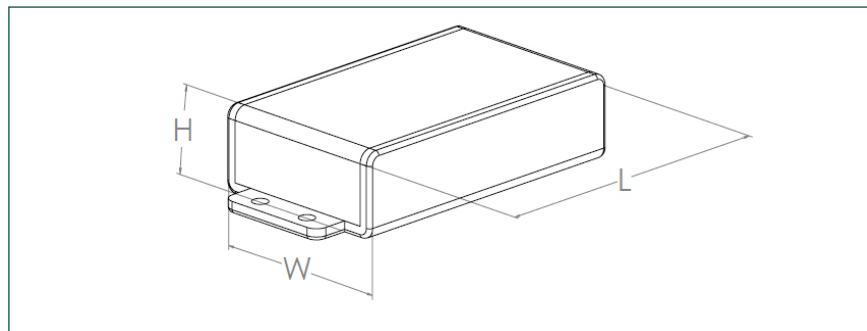
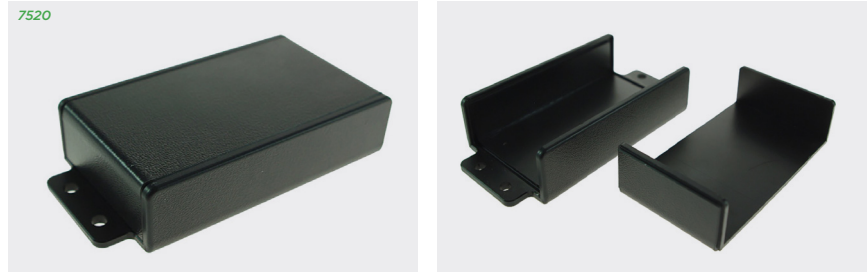

PART NO.	LENGTH (INT)	WIDTH (INT)	HEIGHT (INT)	LENGTH (EXT)	WIDTH (EXT)	HEIGHT (EXT)
7521	75mm	40mm	15mm	76mm	46mm	21mm
7522	100mm	45mm	18mm	106mm	51mm	24mm
7523	120mm	50mm	20mm	126mm	56mm	26mm
7524	150mm	150mm	50mm	156mm	156mm	56mm
7525	220mm	150mm	65mm	226mm	156mm	71mm
Custom size	Please advise dimensions					

Available in a range of colours:



KEY FEATURES

U-shell design | HB as standard V0 optional | Surface mount tabs

